

# Enabling Secure, Real-Time Cross Domain VoIP/Video Communications

## Summary

### INDUSTRY

Department of Defense  
Intelligence Community

### CHALLENGES

Defense network security infrastructure creates communities of users who cannot communicate efficiently outside of their security domain

### SOLUTION

V2CDS - voice over IP and video cross domain solution

### BENEFITS

Secure, efficient, and user-friendly cross domain communication

## Cybersecurity Challenge

Voice over Internet Protocol and point-to-point video are common tools for communication throughout the Department of Defense (DoD) and the Intelligence Community (IC). However, as currently deployed, the DoD infrastructure creates communities of users who cannot communicate outside of their network or security domain. One person would have to use multiple VoIP phones to reach different security domains from a single desk, thus making cross-domain collaboration cumbersome, slow, inefficient, and expensive. The inability of coalition partners to establish real-time cross-domain communication using a VoIP infrastructure not only obstructs operative collaboration, but in extreme scenarios can jeopardize the safety of combat forces in the field.

### REQUIREMENTS

- Secure, real-time cross domain VoIP and point-to-point video communication
- Inline content filtering and bidirectional protocol break
- Collaboration facility re-use (not locked into classification level)
- Real-time collaboration with geographically distributed partner agencies and FVEY coalition community



*Before Architecture*

## Solution

Owl V2CDS provides a solution that delivers cross-domain communication securely, efficiently and in a user-friendly and timely manner. The V2CDS solution enables users to hold two-party direct [one-to-one calls] and multi-party digital voice/audio calls between two security domains and enhances VoIP functionality with added video support. With V2CDS, users initiate, run and securely close point-to-point videophone calls [one-to-one videophone calls] using cross-domain communications. V2CDS also authenticates users, and reduces covert channels to an acceptable risk, while simultaneously maintaining point-to-point video capability.

### V2CDS 2.0

Owl V2CDS is a secure cross domain solution which supports cross-domain voice and video calls, both point-to-point and audio conferencing, between two security domains.

## Results

- Provided secure, efficient and user-friendly cross-domain communication
- Enabled close point-to-point videophone calls using cross-domain communications
- Eliminated travel time and costs for classified meetings
- Reduced infrastructure costs for materials and support services
- Mitigated covert channel risk

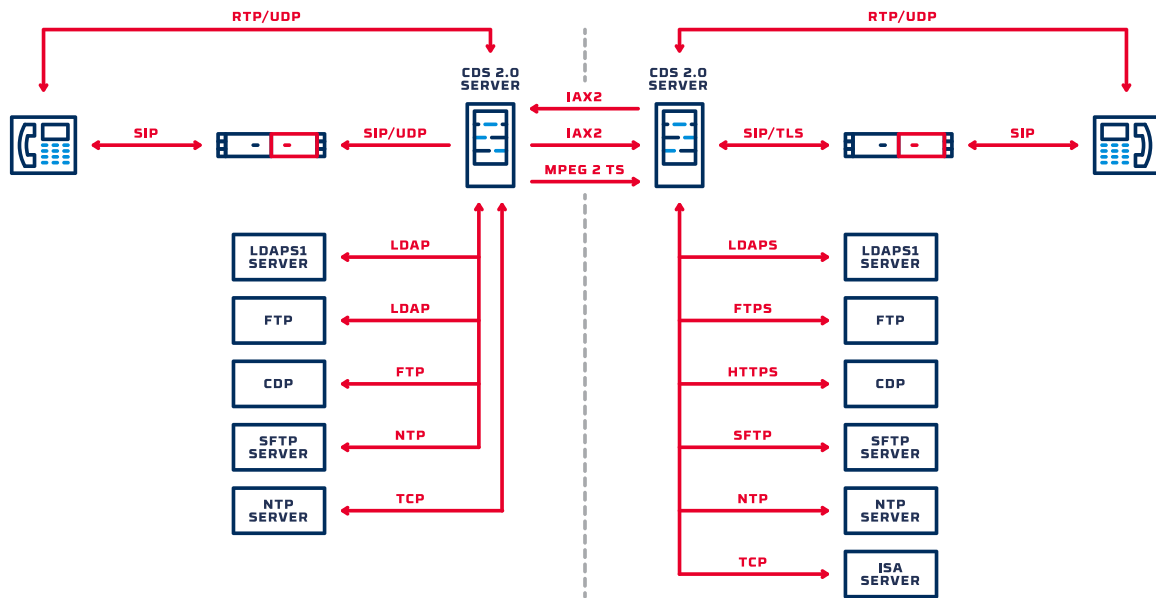

Owl Cyber Defense cross domain, data diode, and portable media solutions provide hardened network security checkpoints for hardened threat prevention and secure data availability. For over 20 years, Owl's unmatched expertise, products, and services have been trusted by clients in government, defense, critical infrastructure, and commercial organizations around the world.

For more information on Owl, or to schedule a demo, visit [www.owlcyberdefense.com](http://www.owlcyberdefense.com)